

MAVIS - Modular Attribute-Value Interchange System

COLLABORATORS

	<i>TITLE :</i> MAVIS - Modular Attribute-Value Interchange System		
<i>ACTION</i>	<i>NAME</i>	<i>DATE</i>	<i>SIGNATURE</i>
WRITTEN BY	Marc Huber	November 12, 2017	

REVISION HISTORY

NUMBER	DATE	DESCRIPTION	NAME

Contents

1	Introduction	1
1.1	Download	1
2	Design overview	1
3	Authentication setups	1
4	Sample setups	2
5	Configuration Syntax	2
5.1	Standard Configuration Directives	3
5.2	Backend Module Configuration	4
5.2.1	The <i>anonftp</i> module	5
5.2.1.1	Configuration directives	5
5.2.1.2	Railroad Diagram	5
5.2.2	The <i>asciiftp</i> module	5
5.2.2.1	Configuration directives	6
5.2.2.2	Railroad Diagram	6
5.2.3	The <i>auth</i> module	6
5.2.3.1	Configuration Syntax	6
5.2.3.2	Railroad Diagram	7
5.2.4	The <i>cache</i> module	7
5.2.4.1	Configuration directives	7
5.2.4.2	Railroad Diagram	7
5.2.5	The <i>external</i> module	8
5.2.5.1	Configuration directives	8
5.2.5.2	Railroad Diagram	9
5.2.6	The <i>group</i> module	9
5.2.6.1	Configuration directives	9
5.2.7	The <i>limit</i> module	10
5.2.7.1	Configuration directives	10
5.2.7.2	Railroad Diagram	10
5.2.8	The <i>log</i> module	10
5.2.9	The <i>PAM</i> module	10
5.2.9.1	Configuration directives	11
5.2.9.2	Railroad Diagram	11
5.2.10	The <i>remote</i> module	11
5.2.10.1	Configuration directives	12

5.2.10.2	Railroad Diagram	13
5.2.10.3	Possible legal restrictions	13
5.2.11	The <i>system</i> module	13
5.2.11.1	Configuration directives	13
5.2.11.2	Railroad Diagram	14
5.2.12	The <i>userdb</i> module	14
5.2.12.1	Configuration directives	14
5.2.12.2	Railroad Diagram	15
5.2.12.3	Example	15
5.2.13	The <i>tee</i> module	16
5.2.13.1	Configuration directives	16
5.2.13.2	Railroad Diagram	16
5.2.14	The <i>null</i> module	17
5.3	MAVIS Scripting Language	17
6	Testing your MAVIS configuration	21
7	Environmental Variables	21
8	Copyrights and Acknowledgements	21

1 Introduction

The MAVIS libraries provide a modular and extensible protocol for authorization and authentication tasks. Authorization/authentication modules are stackable and configurable. Both synchronous and asynchronous operation modes are available.

The modules are reentrant, but not thread-safe.

1.1 Download

Source and documentation are available from <http://www.pro-bono-publico.de/projects/>.

2 Design overview

The MAVIS system consists of the MAVIS library (`libmavis.so`) and various MAVIS modules (`libmavis_*.so`). The library glues the modules together, sends requests to and receives answers from the modules. A module may answer (or modify) a request or pass it on to the module loaded later. It may intercept and modify the response from that module.

Example: Consider the following set-up:

An incoming request, e.g. for FTP authentication, first reaches the `log` module, which simply passes it on to the `limit` module. The `limit` module checks the IP address of the client and rejects the request if that address is blacklisted. Otherwise, the request is passed on to the `auth` module, which leaves it alone and passes it on to the `cache` module. If the request is not cached within the `cache` module it is passed on to the `pam` module, which sets some attribute-value pairs and sends the request back to the `cache` module. The `cache` module in turn adds the request data to its cache database and passes it back the `auth` module for authentication checking. [Remaining steps omitted.]

```

--.                                     .-->
|                                     |
|====|====<log>=====|====|
| |                                     |
| |                                     | log -----' |
| |                                     | request <-----. |
>====|====<limit>=====|====<
| ' --> client IP -----(YES)-----> reject ----->| | |
| .--- blacklisted?          .---> request          | |
| |                                     | |
| (NO)                       (YES)-- add IP to --(NO)--' |
| |                                     | blacklist? <------. |
>====|====<auth>=====|====<
| |                                     | |
| |                                     | verify -----' |
| |                                     | authentication <-----. |
>====|====<cache>=====|====<
| ' --> answer for request --- (YES) ---> answer request -->| | |
| .--- already cached?          | |
| |                                     | |
| (NO)                           cache -----' |
| |                                     | request <-----. |
>====|====<pam>=====|====<
| ' --> retrieve authentication information from -----' |
| PAM sub-system and system files          |
'-----'

```

3 Authentication setups

Some MAVIS modules have both synchronous and asynchronous operation modes. For low and medium performance applications it's sufficient to have one authentication daemon processing all incoming requests, with all the MAVIS modules utilized by

mavisd operating synchronously. However, this introduces a serialization of all queries, causing requests that could immediately be answered by e.g. the limit or cache module to be deferred until database queries got processed. One possible solution to remedy this is to add one or more secondary authentication daemon for asynchronous processing of queries for synchronous-only modules. The remote module automatically distributes queries between the configured MAVIS daemons.

4 Sample setups

1. Stand alone setup: Authentication requests are processed synchronously. Only recommended for low-latency modules where no common database is required, e.g. the anonftp module.

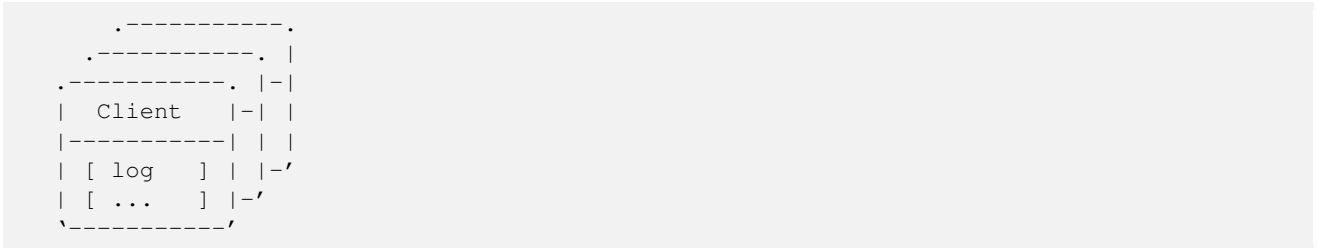

2. Remote authentication setup: Authentication request processing is done asynchronous by *mavisd*. Recommended for medium-latency modules or modules that require access to shared data, e.g. the limit or cache module.

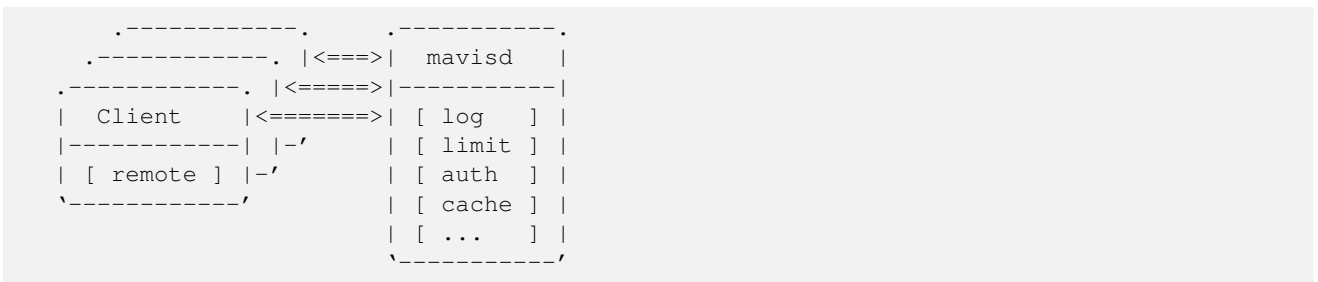

3. Remote authentication setup with redundancy: Recommended for high-latency modules that are only capable of synchronous request processing, high- performance setups or where redundancy is desired, e.g. suitable for database access modules.

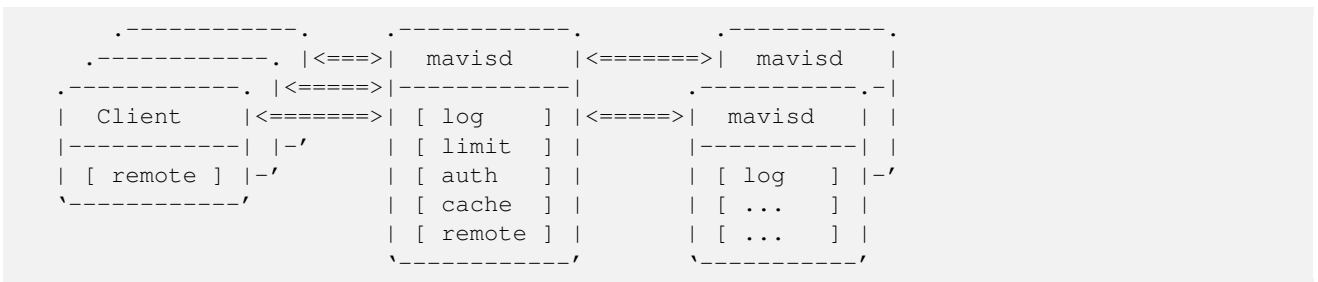

5 Configuration Syntax

MAVIS modules are configured within the context of the application utilizing them. There's no special configuration file required or even supported.

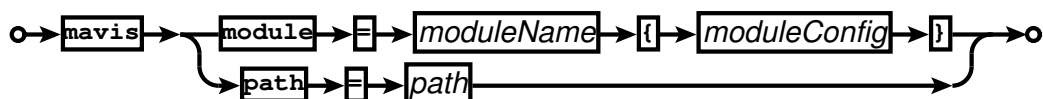

Railroad diagram: MavisDecl

5.1 Standard Configuration Directives

Top-level configuration directives common to all of the applications using the MAVIS interface are:

- `include = config`
Evaluates configuration file `config`.
- `id = ID{ ... }`
Defines a configuration section `ID`, which will be evaluated by a matching server process.

Standard configuration directives which may be used both at top-level and inside the `ID` sections are:

- `alias = name { ... }`
Defines an alias for the configuration directives inside the curly brackets.
- `debug = Level ...`
`Level` can be either a integer value or a sequence of debugging keywords, each of which may, optionally, start with + or -, where + will enable debugging, and - will disable it. Supported keywords and their corresponding integer values are:

PARSE	1
AUTHOR	2
AUTHEN	4
ACCT	8
CONFIG	16
PACKET	32
HEX	64
LOCK	128
REGEX	256
ACL	512
RADIUS	1024
CMD	2049
BUFFER	4096
PROC	8192
NET	16384
PATH	32768
CONTROL	65536
INDEX	131072
AV	262144
MAVIS	524288

Not all of these debugging flags may have an actual effect. The flags are additive; use the special flag `NONE` to clear all flags, use `ALL` to set all flags.

Debugging options may only be available when the package was configured with the `--debug` command line switch.

Example:

```
debug = ALL -PARSE -NET
```

- `regex-match-case = (yes|no)`
Enables/disables case-sensitive regex pattern matching for the current context. Default: `no`.
- `syslog ident = Ident`
Set the `syslog(3)` identity. Defaults to the programs basename.
- `syslog level = Level`
Set the `syslog(3)` level. Default: `INFO`.

- `syslog facility = Facility`
Set the `syslog(3)` facility. Default: UUCP.
- `syslog default = (permit|deny)`
Enables or disables implicit logging to `syslog(3)` (if supported). Default is `permit`.

Standard configuration directives which may be used inside the *ID* section of *MAVIS* enabled applications are:

- `mavis path = Path`
Add *Path* to the module search path.
- `mavis module = ModuleName { ... }`
This directive searches for module *ModuleName* in the compiled-in and configured search paths. Alternatively to auto-search, *ModuleName* may be an absolute path to a MAVIS module. The module will be loaded and will parse the configuration data inside the curly brackets.

An actual configuration could look similar to:

```
syslog level = INFO
syslog facility = DAEMON

id = spawned {
    listen = { port = 21 }
    debug = NET
    background = no
    spawn = { exec = /usr/local/libexec/ftpd }
}

id = ftpd {
    debug = ACL AUTHEN
    mavis path = /some/none/default/location

    mavis module = tee {
        path in = /tmp/av.in
        path out = /tmp/av.out
    }

    mavis module = log {
    }

    mavis module = anonftp {
        userid = 100
        groupid = mail
        home = /
        root = /tmp/
        incoming = /tmp/incoming/
    }

    acl testacl {
        src = 127.0.0.1
    }

    # lots of stuff missing here ...
}
```

5.2 Backend Module Configuration

The following modules are included in the distribution.

5.2.1 The *anonftp* module

This module implements anonymous FTP authentication. If the `cache` module is to be used, it has to be loaded *after* the `anonftp` module, because the `cache` module will only cache FTP type queries compatible with the `auth` module, and queries answered by the `anonftp` module aren't.

5.2.1.1 Configuration directives

The following configuration directives are mandatory, unless a `ftp` user exists in the local password database, in which case that information may be gathered from there:

- `userid = UserID`
- `groupid = GroupID`
- `root = RootDirectory`
- `home = HomeDirectory`

There's one optional directive:

- `upload = UploadPathRegex`

By default, anonymous FTP uploads are denied. The `upload` directive specifies a POSIX regular expression where uploads are permitted.

5.2.1.2 Railroad Diagram

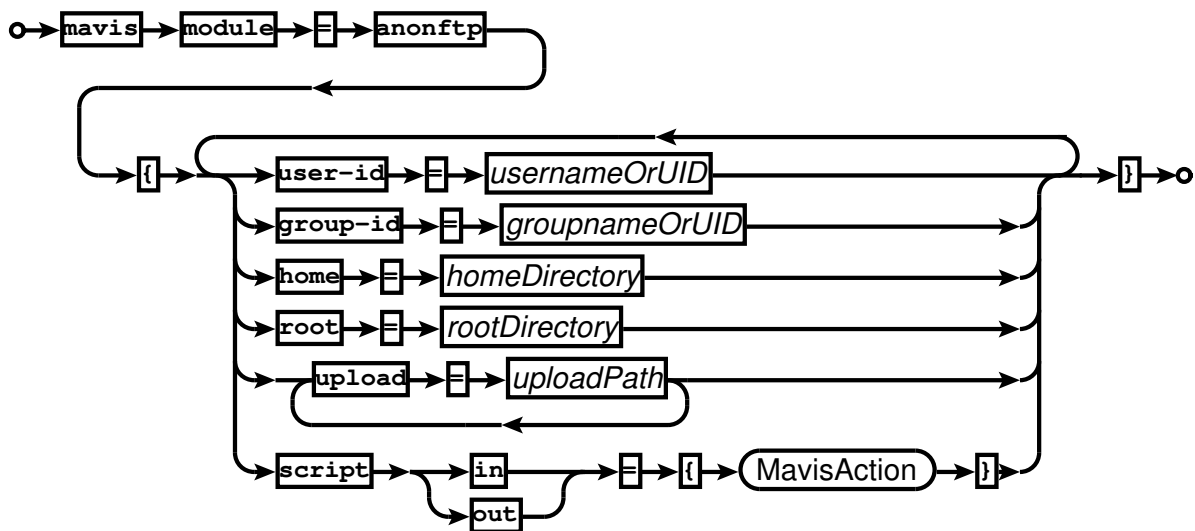

Railroad diagram: *AnonftpConf*

5.2.2 The *asciiftp* module

This module implements FTP authentication via an ASCII file.

5.2.2.1 Configuration directives

- `file = path`

Authentication data is read from *path*. The generic syntax for individual configuration file lines is:

```
user:password:uid:gids:type:root:home[:certsubj]
```

Example file:

```
customer1:whatever:10000:10001:anon:/home/customers/customer1:/
customer2:whatever:10000:10002:anon:/home/customers/customer2://C=DE/ST=...
admin:whatever:10000:10001,10002:real:/home/customers:/admin
```

This configuration directive is mandatory.

- `userid(min|max) UserID`

This directive specifies upper and lower UID limits.

- `groupid(min|max) GroupID`

This directive specifies upper and lower GID limits.

5.2.2.2 Railroad Diagram

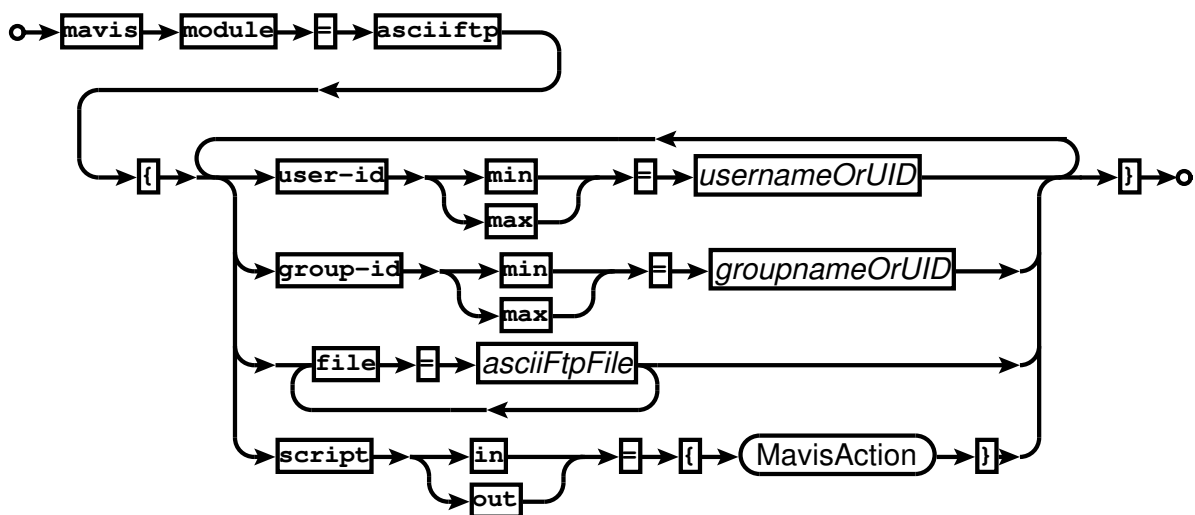

Railroad diagram: ASCIIftpConf

5.2.3 The *auth* module

This module implements the server side of plain text and certificate based authentication schemes.

The *auth* module is mandatory for most authentication to work. It needs to be loaded before any caching or database access module, and it won't work over remote links unless *mavisd* is configured with "transmit-password yes". The *anonftp* and, depending on the backend, the *external* module are the only ones that doesn't require this module to be loaded.

5.2.3.1 Configuration Syntax

The only configuration option available is

- `authentication-mode =cert [sufficient|required]`

This option may be used when authentication via digital certificates (currently supported by the *system* module) is used. If the *sufficient* keyword is used, no additional password authentication is necessary. The *required* keyword makes certificate authentication mandatory

5.2.3.2 Railroad Diagram

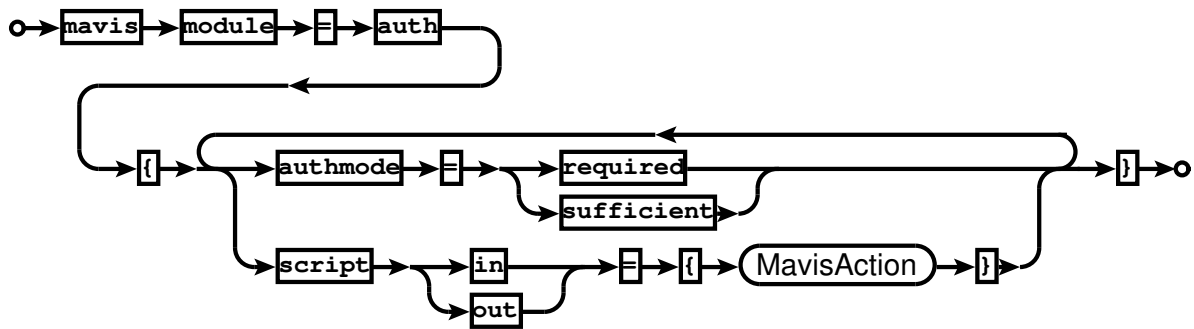

Railroad diagram: AuthConf

5.2.4 The *cache* module

This module stores the most recently answered queries in RAM for faster processing of subsequent queries for the same data. For most applications, it has to be loaded *after* the auth module.

5.2.4.1 Configuration directives

Available configuration directives are:

- `expire [Type] = Seconds`

Specifies the caching period for requests of type *Type* (or of all requests, if no type is given). No caching will be performed unless this directive is given. Valid values for *Type* are: FTP, TACPLUS.

Example:

```
# cache everything 100 seconds by default:
expire = 100
# Don't cache FTP requests:
cache expire FTP = 0
```

- `purge-outdated = Seconds`

Periodically, outdated entries have to be removed from the cache. By default, this happens every 300 seconds, but you may specify a different garbage collection interval.

5.2.4.2 Railroad Diagram

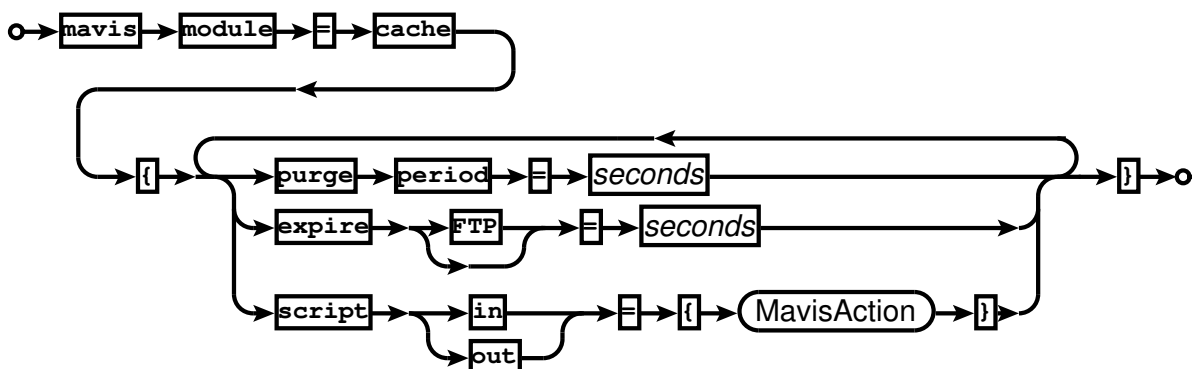

Railroad diagram: CacheConf

5.2.5 The *external* module

This module implements an interface to external authentication programs. An authentication program is expected to read a list of attribute-value pairs on `stdin`, and write the processed list (plus a result code) to `stdout`. The programs `stderr` output will be logged to `syslogd`.

Sample authentication backends for the `external` module include various Perl scripts, e.g. for RADIUS and LDAP authentication (see the `mavis/perl/` directory), plus C backends. The latter are `radmavis` (for RADIUS authentication) and `pammavis` (for PAM authentication, as an alternative to the `PAM` module). While those may not be as flexible and easily to modify as the Perl scripts, they carry far fewer dependencies, and quite a lot of the usual attribute modifications can be performed using scripts; see the Scripting section below.

Using the *external* module to interface to external authenticators is probably in most cases favourable to writing custom modules, as external authentication programs may be implemented as easy-to-deploy Perl programs. Plus, you're likely to get parallelism for free.

Caveat Emptor

Chaining *external* modules in asynchronous mode may not work as expected. Just don't do it.

5.2.5.1 Configuration directives

The following configuration directives are available:

- `userid = UserID`
Set user id of child process to *UserID*.
 - `groupid = GroupID`
Set group id of child process to *GroupID*.
 - `home = Directory`
Change to *Directory* before executing child process.
 - `childs (min|max) = Number`
Set the minimum or maximum number of child processes (defaults: 4, 20).
 - `setenv Variable = Value`
Set environment variables.
 - `exec = Path Arguments ...`
Set path and arguments (including `argv[0]`) of the authentication program. It's recommended to enclose the individual arguments in double quotes if they contain non-alphanumeric characters.
-

5.2.5.2 Railroad Diagram

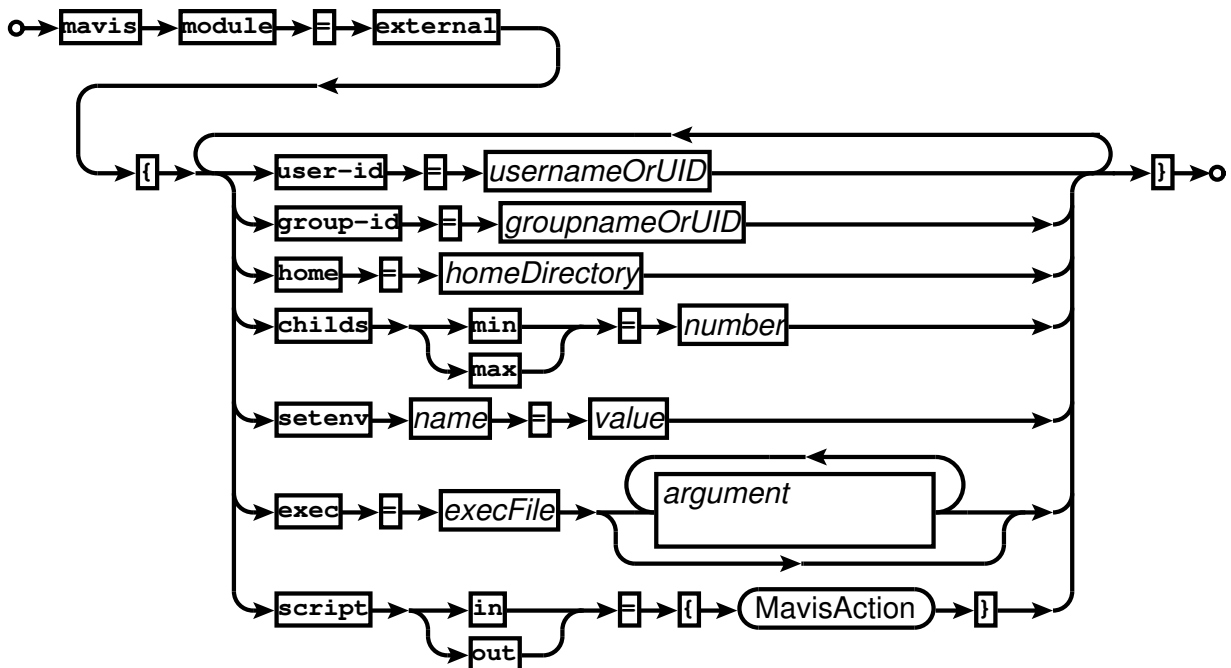

Railroad diagram: ExternalConf

5.2.6 The *group* module

This module resolves numerical group IDs returned by a downstream backend to their corresponding ASCII names.

5.2.6.1 Configuration directives

The following configuration directives are available:

- `resolve gid = (yes|no)`
This tells the module to resolve the primary group id.
- `resolve gids = (yes|no)`
This tells the module to resolve the group access list.
- `gid filter = [not] gid_start[-gid_end][, gid_start[-gid_end]]*`
Establishes a filter on the GID MAVIS attribute. Example:

```
gid filter = 100,1000-1050
```
- `gids filter = [not] gid_start[-gid_end][, gid_start[-gid_end]]*`
Establishes a filter on the GIDS MAVIS attribute. Example:

```
gid filter = 100,1000-1050
```
- `group filter = [not] regex[, regex]*`
Establishes a filter on the GID MAVIS attribute *after* name resolving. Example:

```
group filter = /^com/
```

- `groupx filter = [not] regex[, regex]*`

Establishes a filter on the GIDS MAVIS attribute *after* name resolving. Example:

```
groups filter = /^com/
```

(*regex* syntax in these examples is PCRE, but standard POSIX will work, too.)

5.2.7 The *limit* module

This module implements limitations on the number of failed authentications per IP address.

5.2.7.1 Configuration directives

Available configuration directives are:

- `blacklist time = Seconds`

```
blacklist count = Count
```

This limits the number of failed authentication requests per client IP address to *Count* per *Seconds* interval. Subsequent requests from the same client IP address will be rejected. This is disabled by default.

- `purge-outdated = Seconds`

Periodically, the module will start a garbage collection run in order to remove outdated data from its internal data structures. This directive sets the garbage-collection period to *Seconds* (default: 300).

5.2.7.2 Railroad Diagram

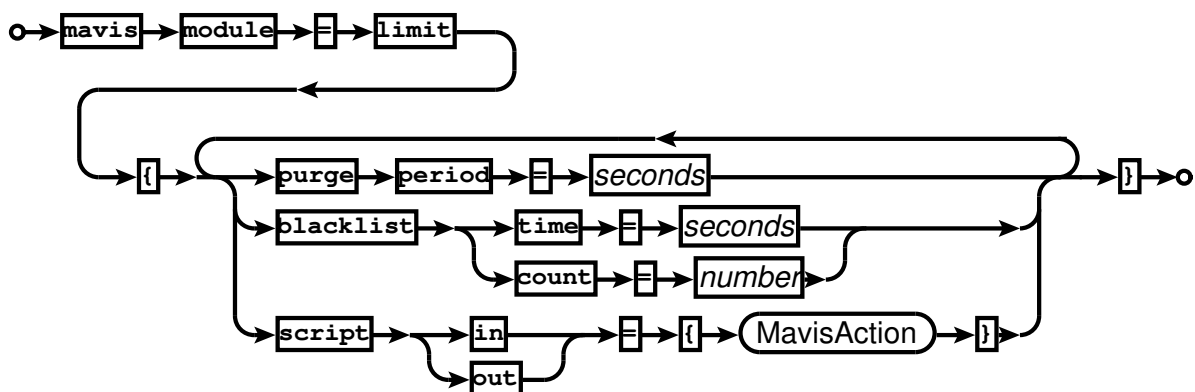

Railroad diagram: *LimitConf*

5.2.8 The *log* module

This module performs query logging to **syslogd**. There are no configuration options.

5.2.9 The *PAM* module

This module implements an interface for FTP authentication via pluggable authentication modules (PAM). The *PAM* module doesn't support asynchronous operation; you might be better off using the *external* module in conjunction with the `pamnavis` program, giving you parallelism and a lot more flexibility for free.

PAMs that perform queries other than the standard username/password aren't supported.

Please take care not to use PAM modules with login delays enabled. E.g., for the `pam_unix` module, configure your PAM subsystem to use the `nodelay` (or whatever it's called in your setup) option, e.g. in `/etc/pam.conf`:

```
mavis required pam_unix.so nodelay
```

or in `/etc/pam.d/mavis` (or whatever service you've specified, see below):

```
auth    required    pam_unix.so nodelay
account required    pam_unix.so
password required    pam_unix.so
session required    pam_unix.so
```

On MacOS, the following should work:

```
auth    required    pam_opendirectory.so
account required    pam_opendirectory.so
password required    pam_opendirectory.so
session required    pam_opendirectory.so
```

Pluggable Authentication Modules

Configuring PAM correctly is pretty system specific. Do not assume that one of the examples above will work on your box. Have a look at your existing PAM configurations instead, and read the documentation that comes with your system.

Programs utilizing this module may have to run under the user id of root if access to the shadow password file is required.

5.2.9.1 Configuration directives

Available configuration options are:

- `chroot = (yes | no)`

This activates a chroot environment for PAM users (default: `yes`). The chroot root directory is either the users' home directory or, if the home directory path contains a `./.` sequence, the directory denoted by the path up to that sequence.

- `service = Service`

This specifies the service name to use for PAM initialization. It defaults to `mavis`.

5.2.9.2 Railroad Diagram

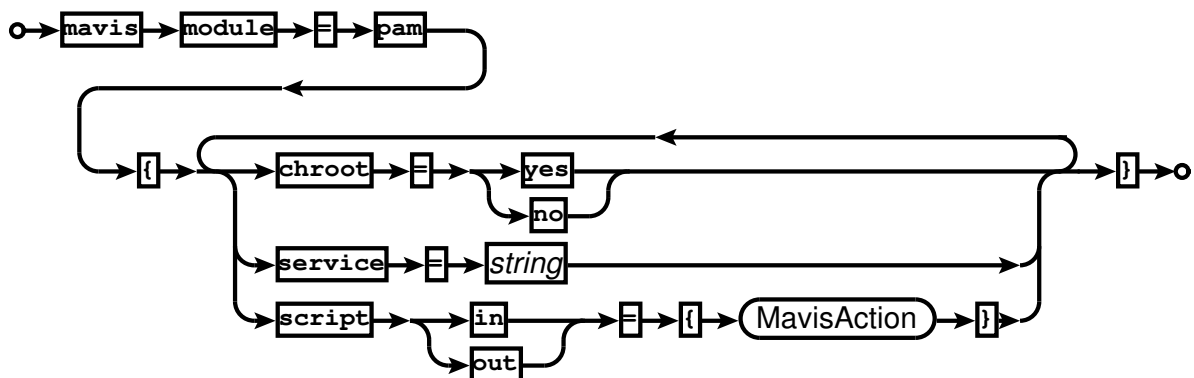

Railroad diagram: PAMConf

5.2.10 The *remote* module

This module implements communication with `mavisd`.

5.2.10.1 Configuration directives

Available configuration options are:

- `local address = IPAddress`

Set address for outgoing IP connections.

- `rebalance = Count`

Re-balances peers after *Count* requests. May be used to reactivate dead peers. Use with care.

Default: unset.

- `server = { ... }`

Specifies a server **mavisd** runs on. Inside the curly brackets, the following directives are permitted:

– `path = UnixPath`

– `address = IPAddress`

– `port = UDPPort`

– `blowfish key = Key`

– `blowfish keyfile = KeyFile`

These set remote connection endpoint and blowfish key. This directive may be used multiple times. Communication will be Blowfish encrypted if a key is specified.

Communication via PF_UNIX sockets may only work if the host system supports anonymous binds for that protocol family. This works on Linux, which supports an abstract namespace which is independent of the file system, but may or may not be an option on other operating systems.

- `timeout = Seconds`

Sets the maximum number of seconds to wait for a response from one of the remote peers. Defaults to: 5.

- `tries = Count`

Sets the maximum number of attempts to get a response from one of the remote peers. Default is 6 tries.

5.2.10.2 Railroad Diagram

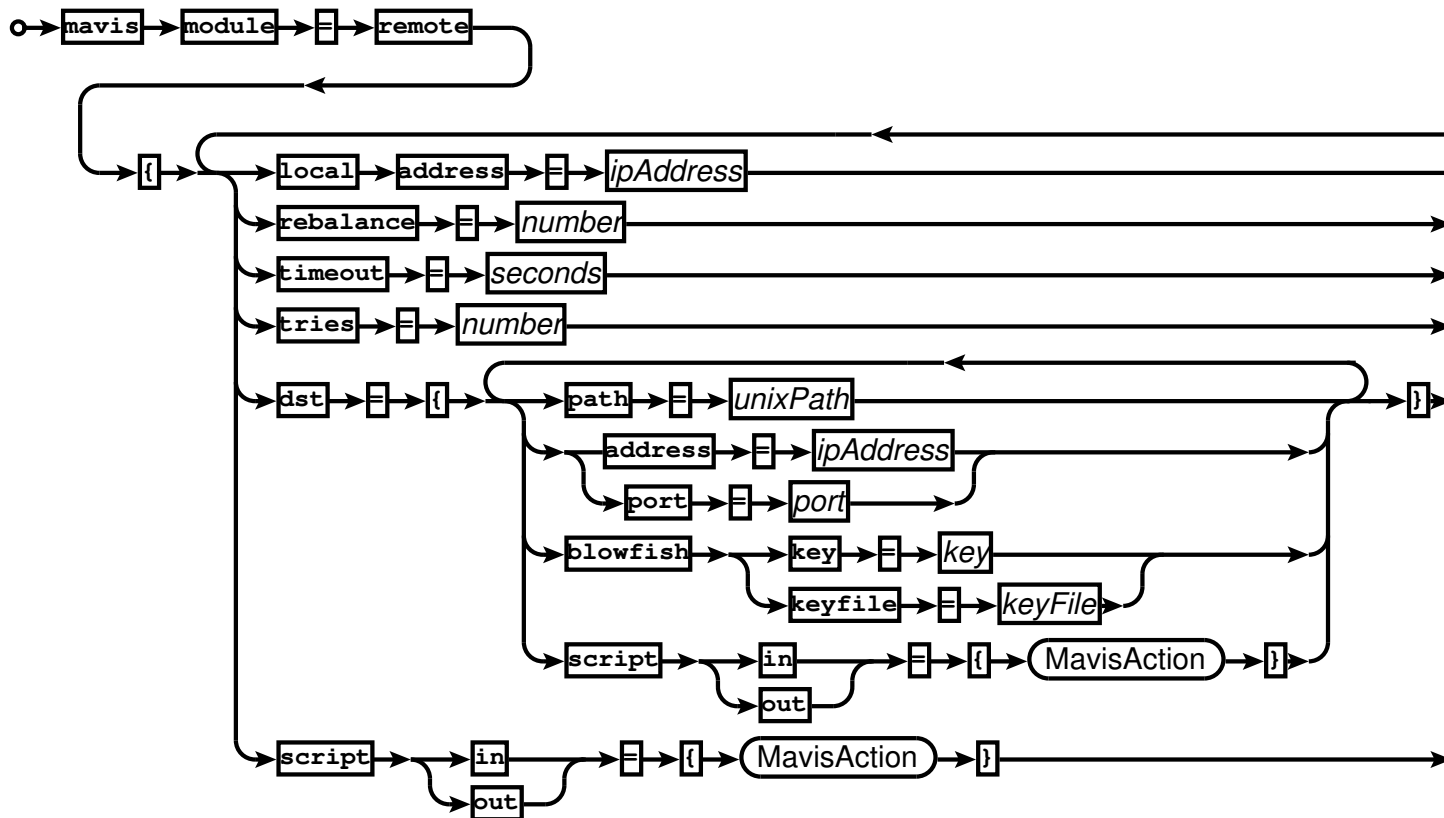

Railroad diagram: RemoteConf

5.2.10.3 Possible legal restrictions

This module utilizes Bruce Schneier's Blowfish algorithm. Your government may have chosen to implement ridiculous legal restrictions regarding use or export of cryptographic software. Take care.

5.2.11 The system module

This module implements FTP authentication via UNIX system accounts or accounts defined in UNIX password-style files. Optionally, certificate based authentication is available. Please note that the `pam` module may be a better choice for most installations.

Programs utilizing this module will most likely have to run under the user id of root if access to the shadow password file is required.

5.2.11.1 Configuration directives

- `chroot = (yes | no)`
This activates a chroot environment for system users (default: `yes`). The chroot root directory is either the users home directory or, if the home directory path contains a `/./` sequence, the directory denoted by the path up to that sequence.
- `ftpusers file = Path`
Select ftpusers file (default: `/etc/ftpusers`).
- `passwd file = Path`
Select UNIX password file. If this is omitted, the systems UNIX accounts are used. On *BSD systems you may wish to set `path` to `/etc/master.passwd`.

- `shells file = Path`
Select shells file (default: `/etc/shells`).

- `sslusers file = Path`
Select sslusers file (default: `/etc/ssl.users`).

The `sslusers` file is compatible to the one proposed by Tim Hudson (tjh@cryptsoft.com) in his SSLeay patches to the BSD ftp daemon. It contains lines of the form

```
user1,user2:/C=US/....
```

where `user1` and `user2` are user names, and the `/C=US/....` part is a certificate subject.

In case you're unfamiliar with OpenSSL: you may retrieve the certificate subject of a certificate `cert.pem` using

```
openssl x509 -subject -noout -in cert.pem
```

- `check (ftpusers | shells | sslusers) = (yes | no)`
Enables checking of the specified file type.

5.2.11.2 Railroad Diagram

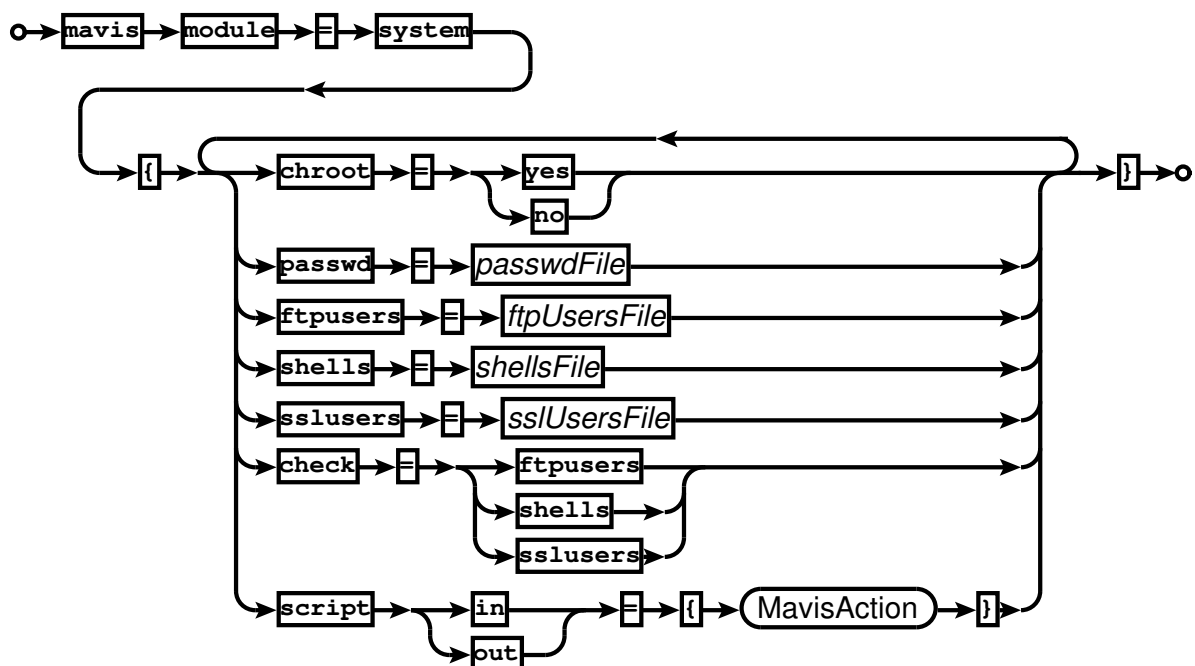

Railroad diagram: `SystemConf`

5.2.12 The `userdb` module

This module can be used to define static users, e.g. for FTP. It requires the `auth` module for user authentication.

5.2.12.1 Configuration directives

Syntax for defining users is `user = UserName { ... }`. The following configuration directives inside the curly brackets are mandatory for FTP, but not enforced:

- `userid = UserID`

- `groupid = GroupID`
- `home = HomeDirectory`
- `password = ((clear|crypt) PasswordString) | mavis`
`clear` indicates a clear-text password, while `crypt` tells the parser that `PasswordString` is DES (or MD5) encrypted. The `mavis` keyword expects the password to be set by a downstream module.

Optional directives are:

- `root = RootDirectory`
- `cert subject = CertSubject`

Arbitrary other MAVIS attributes may be set with

- `set AttributeName = Value`

5.2.12.2 Railroad Diagram

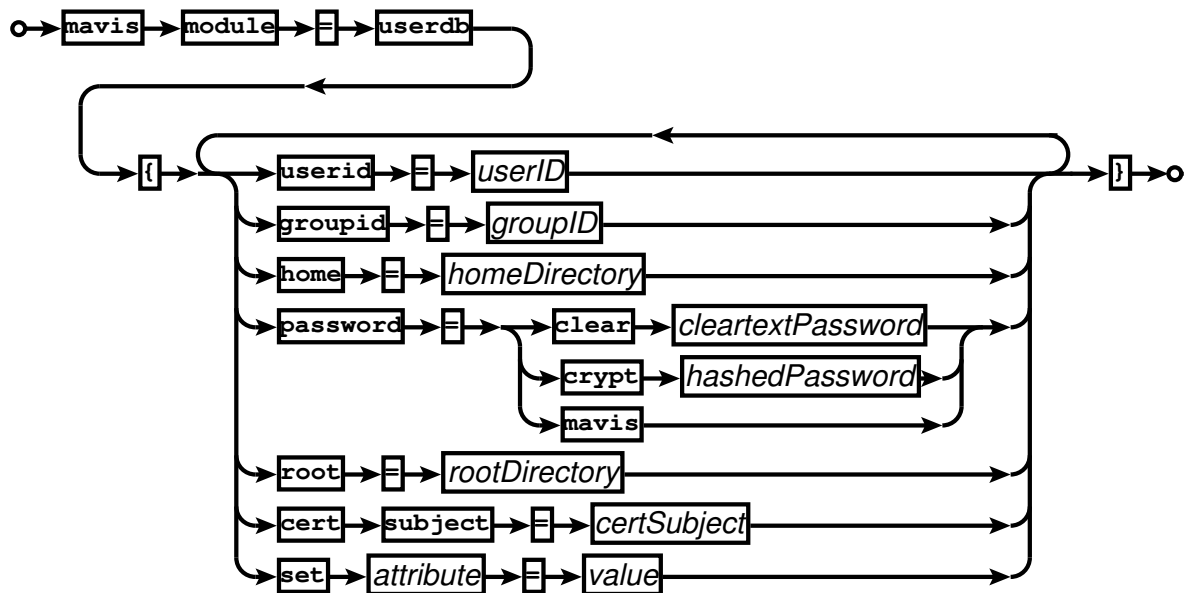

Railroad diagram: `UserDBConf`

5.2.12.3 Example

The following is a valid configuration for `ftpd` which utilizes various MAVIS backends:

```
id = spawnnd {
  listen = { port = 21 }
  spawn = { instances min = 1 }
  background = no
}

id = ftpd {
  mavis path = ../../mavis/obj.%0

  mavis module = anonftp {
    userid = 100
    groupid = 100
  }
}
```

```

    root = /tmp/
    home = /
    upload = /tmp/incoming/
}
mavis module = auth {
}
mavis module = userdb {
    user = test {
        #password = clear test
        password = crypt $1$j/K5hg12$vyCmLeqUzQmr9DdyPTn01.
        root = /tmp/
        home = /
        userid = 100
        groupid = 100
    }
}
symlinks = all
check-uid = no
check-gid = no
check-perm = no
}

```

5.2.13 The tee module

This module is used for development only. It writes sent and received attribute-value pairs to disk in a format which may, for example, be used to test external authenticators (see the description of the *external* module).

5.2.13.1 Configuration directives

Available configuration options are:

- `userid = UserID`
- `groupid = GroupID`
- `mode = Mode`
- `path(in|out) Path`

5.2.13.2 Railroad Diagram

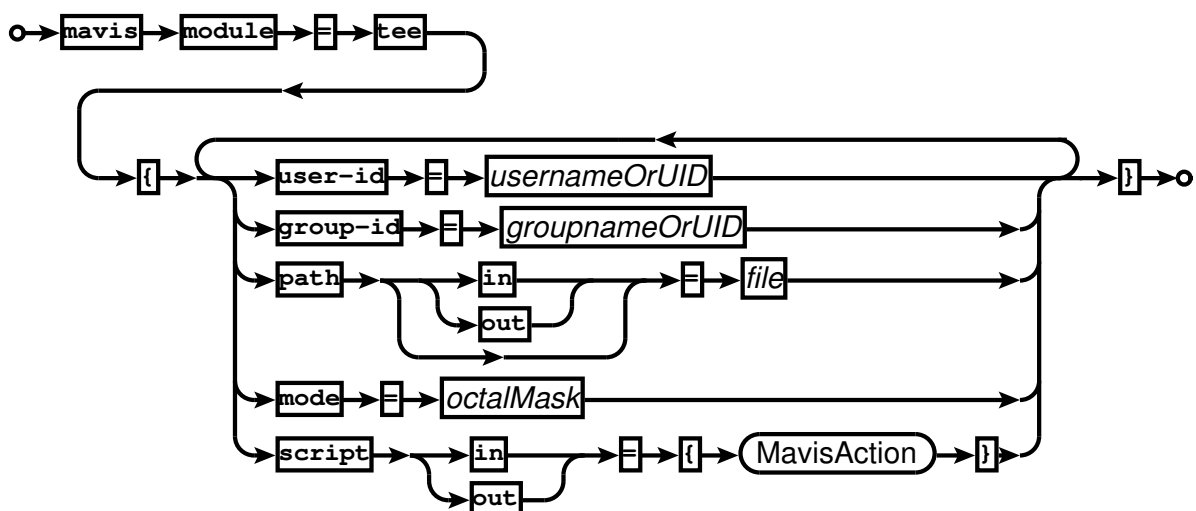

Railroad diagram: TeeConf

5.2.14 The *null* module

This module comes without any functionality on its own. It may however be used in conjunction with the scripting feature described below.

5.3 MAVIS Scripting Language

All MAVIS modules in the distribution come with some basic scripting language support for modifying AV pair and/or module behavior. Scripts can be called when entering or leaving a module and are defined using the `script` keyword.

Generic syntax for the scripting feature is:

```
script ( in | out ) = { action+ }
```

Valid *actions* are:

- { *action+* }
Defines an action block consisting of multiple actions.
- `continue`
Stops processing the remainder of the script and continues with regular module operation.
- `return`
Stops processing the remainder of the script and returns the currently set attributes to the caller.
- `skip`
Skips this module and continue with the next one.
- `set attribute = value`
Sets the specified MAVIS attribute. If the software was compiled with PCRE support (strongly recommended!), the strings \$1 ... \$9 will be replaced with the substrings from the latest *condition* matching operation.
- `unset attribute`
Clears the specified MAVIS attribute.
- `reset attribute`
Resets the specified MAVIS attribute to its original value.
- `toupper attribute`
Converts the specified MAVIS attribute to upper case.
- `tolower attribute`
Converts the specified MAVIS attribute to lower case.
- `eval condition`
Evaluates *condition*, and populates the PCRE substring information vector (\$1 ... \$9).
- `if (condition) action [else action]`
Evaluates *condition* and executes one of the *actions*, if any.

Syntax for *condition*:

- `! condition`
Boolean negation.
 - `condition && condition`
Boolean AND.
-

- *condition* | | *condition*
Boolean OR.
- *attribute* == (*attribute* | *value*)
Exact match.
- *attribute* != (*attribute* | *value*)
No exact match.
- *attribute* =~ *regex*
Exact match. Enclose *regex* in / for PCRE.
- *attribute* !~ *regex*
No exact match.
- *defined* (*attribute*)
TRUE if attribute is set, false else.
- *undef* (*attribute*)
TRUE if attribute is not set, false else.

At least the top-level *condition* needs to be enclosed in round brackets.

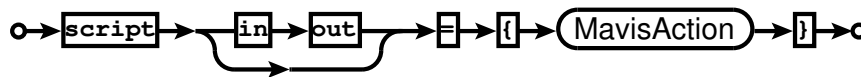

Railroad diagram: MavisScript

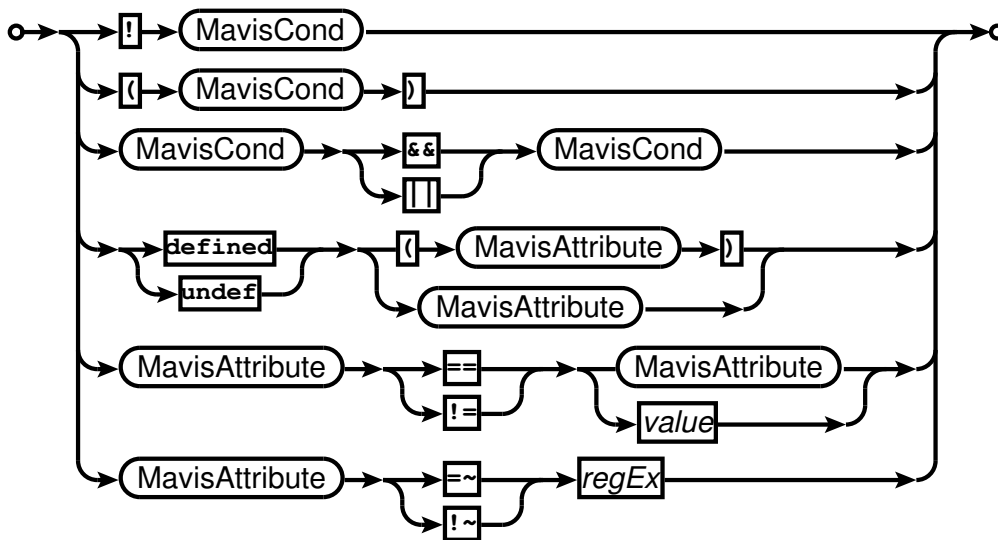

Railroad diagram: MavisCond

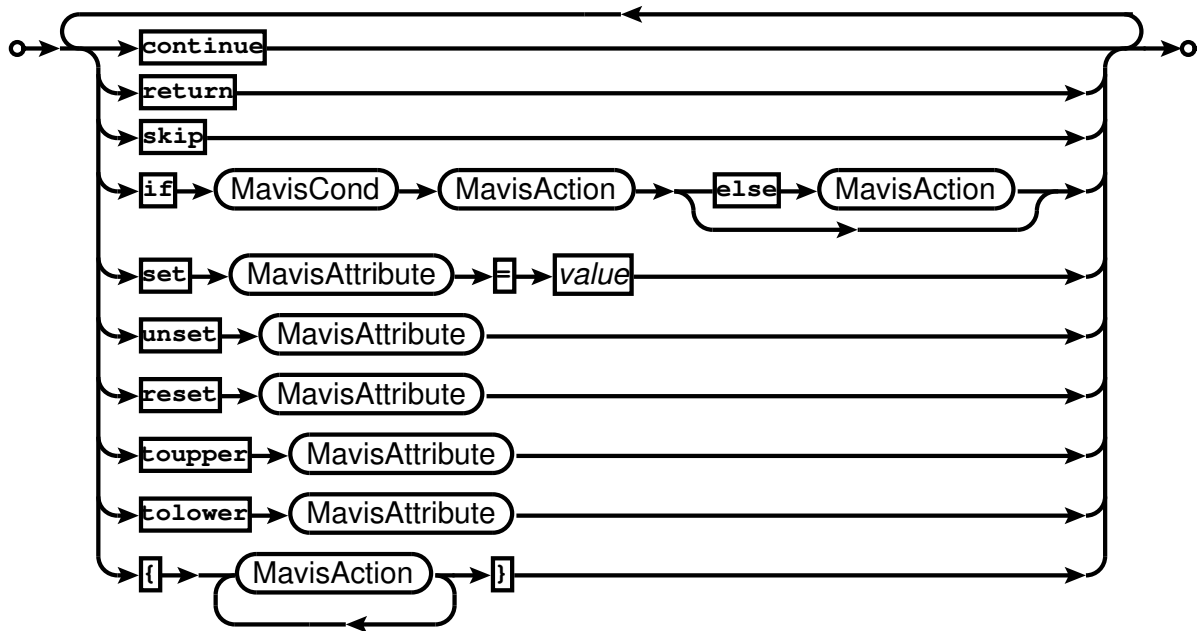

Railroad diagram: `MavisAction`

Here's a sample configuration for FTP authentication via RADIUS, using the `radmavis` binary, called via the external module:

```
mavis module = external {
  script in = {
    if ( $TYPE == FTP ) {
      # Make sure $USER is a) lowercase and b) in user@realm format.
      # This isn't mandatory; I just want to show how to do it:
      tolower $USER
      if ( $USER =~ /^[^\[\]\+]\+\\\\\\\\(.*?)$/ )
        set $USER = $2@$1
      else if ( $USER !~ /^[^@]+\+@(.*)$/ ) {
        eval ( $USER =~ /^.*$/ )
        set $USER = $1@myrealm
      }
    }
  }
  script out = {
    if ( $TYPE == FTP && $PASSWORD == $DBPASSWORD ) {
      set $ROOT = /export/home
      eval ( $USER =~ /^.*$/ )
      set $HOME = /$1
      set $UID = 100
      set $GID = 100
      set $GIDS = "100,102,129"
      set $RESULT = ACK
      # Reset the username to the original value, or upstream
      # will complain:
      reset $USER
    }
  }
  exec = /usr/local/sbin/radmavis radmavis "authserver=localhost:1812:mYrAdIuSsEcReT"
}
```

Note that backslashes in regular expressions need to be doubled.

Likewise, the `pammavis` program may be used for authentication using PAM. Example for TACACS+:

```

mavis module = external {
    script out = {
        # This is actually no longer necessary for recent versions
        if ($TYPE == TACPLUS) {
            if ($TACTYPE == AUTH && $PASSWORD == $DBPASSWORD || $TACTYPE == INFO) {
                set $RESULT = ACK
                # If you're working with "password = mavis" in user profiles
                # and have all users defined locally, there's no need to set
                # any particular TACPROFILE value and you may omit the next
                # line:
                set $TACPROFILE = "{ member = noc }"
            }
        }
    }
    exec = /usr/local/sbin/pammavis pammavis -s pamservicename
    # Optionally: If tac_plus only queries for attributes and we don't
    # evaluate those set by pammavis, then there's no use in calling the
    # latter at all. The "return" will continue with the "out" script:
    script in = { if ($TYPE == TACPLUS && $TACTYPE == INFO) return }
}

```

As detailed in the *PAM* module section above, take care not to use a PAM service which implements login delays. The PAM service can be selected using the `-s pamservicename` option and defaults to `mavis`. PAMs that perform queries other than the standard username/password aren't supported.

A more sophisticated (and complete) example for TACACS+:

```

id = spawnnd { listen = { port = 49 } }

id = tac_plus {
    mavis module = groups {
        resolve gids = yes
        groups filter = /^(guest|staff)$/
        script out = {
            # copy the already filtered UNIX group access list to TACMEMBER
            eval $GIDS =~ /^(.*)$/
            set $TACMEMBER = $1
        }
    }
    mavis module = external {
        exec = /usr/local/sbin/pammavis pammavis -s mavis
    }
    user backend = mavis
    login backend = mavis
    host = global { address = 0.0.0.0/0 key = mykey }

    group = staff {
        service = shell {
            default command = permit
            default command = permit
            set priv-lvl = 15
        }
    }
    group = guest {
        service = shell {
            default command = deny
            set priv-lvl = 15
            cmd = show { permit .* }
        }
    }
}

```

Another example script emulates the `anonftp` module functionality:

```
mavis module = null {
  script in = {
    if ($TYPE == FTP && ($USER == ftp || $USER == anonymous)) {
      set $RESULT = ACK
      set $FTP_ANONYMOUS = TRUE
      set $EMAIL = $PASSWORD
      set $ROOT = /public/ftp
      set $HOME = /
      set $UID = 123
      set $GID = 123
      return
    }
  }
}
```

See `mavis/mavis.h` for a list of supported attributes.

6 Testing your MAVIS configuration

You'll almost certainly want to validate that your backend configuration behaves as expected. You can do so using the `mavistest` binary. Syntax is:

```
mavistest [options] <config> <id> <type> <user> [<password>]
```

Options:

```
-P                (parse only)
-d <debuglevel>  (set debug level)
```

Valid <type> values: FTP, TACPLUS

```
Sample usage: mavistest -d -1 /usr/local/etc/tac_plus.cfg tac_plus TACPLUS joe p4ssw0rd
```

7 Environmental Variables

Text enclosed in double quotes may make use of environment variables, e.g.:

```
filename = "${HOME}/log.txt"
```

The braces are required.

8 Copyrights and Acknowledgements

Please see the source for copyright and licensing information of individual files.

- **The following applies if the software was compiled with TLS support:**

This product includes software developed by the OpenSSL Project for use in the OpenSSL Toolkit.

(<http://www.openssl.org/>)

This product includes cryptographic software written by Eric Young (ey@cryptsoft.com).

- **If the software was compiled with PCRE (Perl Compatible Regular Expressions) support, the following applies:**

Regular expression support is provided by the PCRE library package, which is open source software, written by Philip Hazel, and copyright by the University of Cambridge, England.

(<ftp://ftp.csx.cam.ac.uk/pub/software/programming/pcre/>).

- **MD5 algorithm**

The software uses the RSA Data Security, Inc. MD5 Message-Digest Algorithm.

- **The Blowfish algorithm:**

This software uses Bruce Schneier's Blowfish algorithm.

- **md5crypt:**

```
"THE BEER-WARE LICENSE" (Revision 42):  
<phk@login.dknet.dk> wrote this file. As long as you retain this notice you  
can do whatever you want with this stuff. If we meet some day, and you think  
this stuff is worth it, you can buy me a beer in return. Poul-Henning Kamp
```

- **Portions of the parsing code are taken from Cisco's tac_plus developers kit which is distributed under the following license:**

Copyright (c) 1995-1998 by Cisco systems, Inc.

Permission to use, copy, modify, and distribute this software for any purpose and without fee is hereby granted, provided that this copyright and permission notice appear on all copies of the software and supporting documentation, the name of Cisco Systems, Inc. not be used in advertising or publicity pertaining to distribution of the program without specific prior permission, and notice be given in supporting documentation that modification, copying and distribution is by permission of Cisco Systems, Inc.

Cisco Systems, Inc. makes no representations about the suitability of this software for any purpose. THIS SOFTWARE IS PROVIDED ``AS IS'' AND WITHOUT ANY EXPRESS OR IMPLIED WARRANTIES, INCLUDING, WITHOUT LIMITATION, THE IMPLIED WARRANTIES OF MERCHANTABILITY AND FITNESS FOR A PARTICULAR PURPOSE.

- **The code written by Marc Huber is distributed under the following license:**

Copyright (C) 1999-2015 Marc Huber (Marc.Huber@web.de). All rights reserved.

Redistribution and use in source and binary forms, with or without modification, are permitted provided that the following conditions are met:

1. Redistributions of source code must retain the above copyright notice, this list of conditions and the following disclaimer.
2. Redistributions in binary form must reproduce the above copyright notice, this list of conditions and the following disclaimer in the documentation and/or other materials provided with the distribution.
3. The end-user documentation included with the redistribution, if any, must include the following acknowledgment:

This product includes software developed by Marc Huber (Marc.Huber@web.de).

Alternately, this acknowledgment may appear in the software itself, if and wherever such third-party acknowledgments normally appear.

THIS SOFTWARE IS PROVIDED ``AS IS'' AND ANY EXPRESSED OR IMPLIED WARRANTIES, INCLUDING, BUT NOT LIMITED TO, THE IMPLIED WARRANTIES OF MERCHANTABILITY AND FITNESS FOR A PARTICULAR PURPOSE ARE DISCLAIMED. IN NO EVENT SHALL ITS AUTHOR BE LIABLE FOR ANY DIRECT, INDIRECT, INCIDENTAL, SPECIAL, EXEMPLARY, OR CONSEQUENTIAL DAMAGES (INCLUDING, BUT NOT LIMITED TO, PROCUREMENT OF SUBSTITUTE GOODS OR SERVICES; LOSS OF USE, DATA, OR PROFITS; OR BUSINESS INTERRUPTION) HOWEVER CAUSED AND ON ANY THEORY OF LIABILITY, WHETHER IN CONTRACT, STRICT LIABILITY, OR TORT (INCLUDING NEGLIGENCE OR OTHERWISE) ARISING IN ANY WAY OUT OF THE USE OF THIS SOFTWARE, EVEN IF ADVISED OF THE POSSIBILITY OF SUCH DAMAGE.